

ROLLER DATA SHEET

COMPANY:

CONTACT:

PHONE #:

EMAIL:

APPROVED FOR MANUFACTURE BY:

DATE:

SIGNATURE:

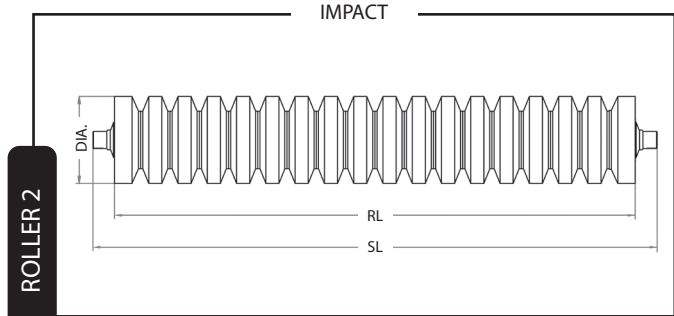
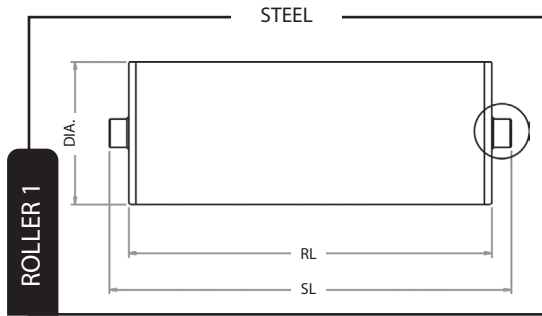

CHOOSE YOUR ROLLER

CHECK ONE

ROLLER 1 — STEEL

ROLLER 2 — IMPACT/DISC CARRYING

ROLLER 3 — RUBBER/URETHANE DISC RETURN

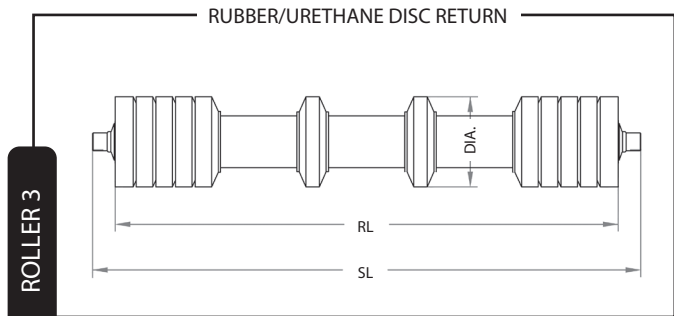

CHOOSE YOUR STYLE

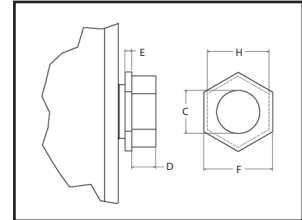
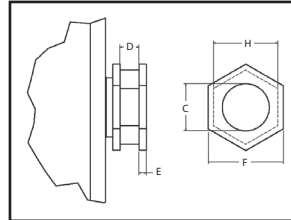
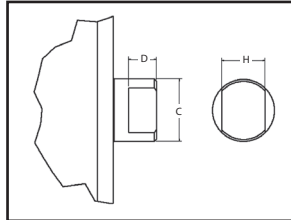
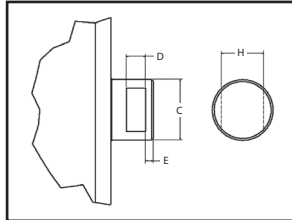

CHECK ONE STYLE A

STYLE B

STYLE C

STYLE D

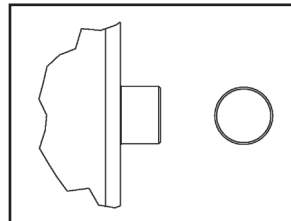
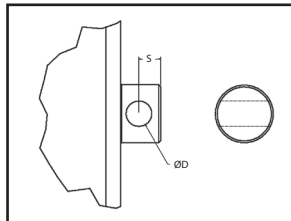
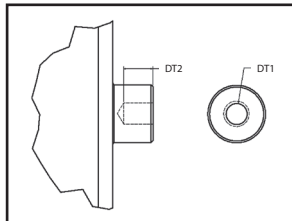

STYLE E

STYLE F

STYLE G



QUESTIONS?
Call Toll-Free: 1.888.349.5833

QUANTITY	IDLER DIA.	ROLLER LENGTH (RL)	SHAFT LENGTH (SL)	CEMA SERIES	SHAFT DIA. (C)	LENGTH OF SLOT (D)	LENGTH OF SHOULDER (E)	HEX FLAT WIDTH (F)	THICKNESS OF SLOT (H)

OR

ADAPTER NUMBER

When STYLE E or F is used, replace above dimensions with: DT1 DT2 S ØD

NOTES: